

# Rail King®

## MOBILE RAILCAR MOVER

# RK285 <sup>G5</sup>

## Rail King Model RK285 G5 Mobile Railcar Mover

Provides up to 44,500 pounds of tractive effort

### Design Features

- Cummins QSB Tier 4i Engine
- Four Speed Automatic Transmission
- Royalglide operator comfort system
- Patented Cushion Coupler system
- Friction roadwheel drive
- Full width bumpers to protect powertrain
- Fabricated steel couplers
- Ergonomically designed side mount cab layout
- Unsurpassed operator visibility
- Easy to use push button controls with color LCD display

### Options

- Air conditioning
- Remote control
- Air-ride seats
- Central lube system
- Cold Weather protection package
- Step extensions
- Spotlights
- Turn signals
- Fire extinguisher
- 75-gallon (283 liters) fuel tank
- 100 CFM air compressor
- Other options available upon request



See Back For Product Specifications



[www.stewartandstevenson.com](http://www.stewartandstevenson.com)

# Rail King Model RK285 G5

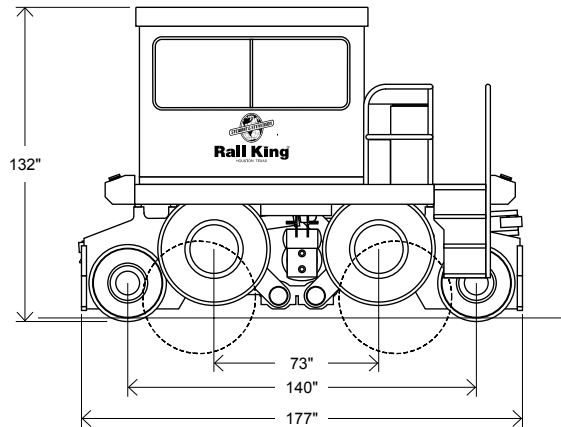
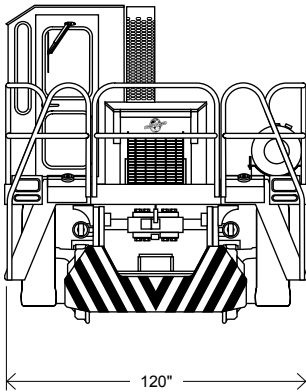

## Railwheels

28" diameter heat-treated cast steel. Tapered tread contour to AAR specifications.

## Roadwheels

Heavy duty rock lug industrial tires.

## Pneumatic System

High capacity 50-cfm air compressor system. Includes two compressors, three reservoirs with drains, air dryers, lever operated pressure control valve with emergency stop capability.

## Power Steering

Full hydrostatic power steering with improved turning radius.

## Couplers

Two weight-transfer couplers made from fabricated steel (no castings). Couplers slide on high-density self-lubricating nylon bearings for long life and minimal maintenance. This heavy-duty coupler system operates on a center pivot housed in a massive synthetic rubber cushion pressed into both sides of the frame.

## Sanders

Large capacity, replaceable steel sandboxes and eight air-operated sanding tubes with easy clean receivers: two for each rail wheel, front and back.

## Dual-direction Cab

Provides excellent visibility. Improved height for ease of moving around. Standard equipment includes dual controls, one-piece dual seat providing more adjustment for operator, front and rear wipers, heater, two defrost fans and tempered safety glass. Full size doors permit easy access in and out of cab.

## Controls

Improved console layout with full color LCD display, multicolor LED rocker switch panels, canbus electrical system with PLC based mobile controller. Allows operators to view real-time engine, transmission and Rail King operating parameters, as well as active and stored trouble/diagnostic codes.

## Other Features

Air blast horn and full light package, including strobe light.

## SPECIFICATIONS

### GENERAL

Weight	37,000 lb
Length	177"
Width	120"
Height (on road)	142"
Height (on rail)	132"
Rail Clearance	3"
Road Clearance	10"
Speeds (Forward & Reverse)	4
On road	9 mi/h
On rail	15 mi/h

### ENGINE

Make	Cummins
Model	QSB 6.7
Type	Electronic, 4-cycle, turbocharged diesel
Rated Power	173 bhp @ 2500 rpm
Fuel Tank	40 gal
Features	US EPA Tier 4i (EU Stage IIIB) compliant

### MAXIMUM TRACTIVE EFFORT

When both couplers are used	44,500 lb
When one coupler is used	28,250 lb

## Frame

Heavy-duty, welded from 2" steel plate

## Engine

Cummins fully integrated air-intake-to-exhaust aftertreatment low emission engine. Electronic management system provides better fuel economy, reduced particulate matter and lower NOx emissions. Utilizes Ultra Low Sulfur Diesel fuel.

## Transmission

John Deere/Funk DF150 with torque converter, four speeds forward and reverse; autoshift or powershift speed selection, operator controlled start in second feature.

## Rail- & Road-Drive

John Deere spiral bevel gear set; designed for bi-directional operation, no spin differential with internal planetary axles. Friction drive transmitted from rail-drive axle incorporates separate braking system. Does not require special tires. Rail shock absorption system standard.

## Brakes

Rail wheel axle: Inboard multiple wet-disk brakes. Protected from contaminants and can last up to four times longer than dry-disk brakes. Spark-free for regulatory compliance in hazardous environments.

Road wheel: heavy-duty disk and caliper style, hydraulic actuated

Train Air Brakes: Push button operated to release or fully apply, modulating hand valve for controlled apply/release.

## Contact us today.

### Stewart & Stevenson Rail King

Telephone: 713-671-6300

Facsimile: 713-671-6386

www.railking.net

email: railking@ssss.com

8787 East Freeway

Houston, TX 77029



www.stewartandstevenson.com